

# **PROXXON**

**MF 70**

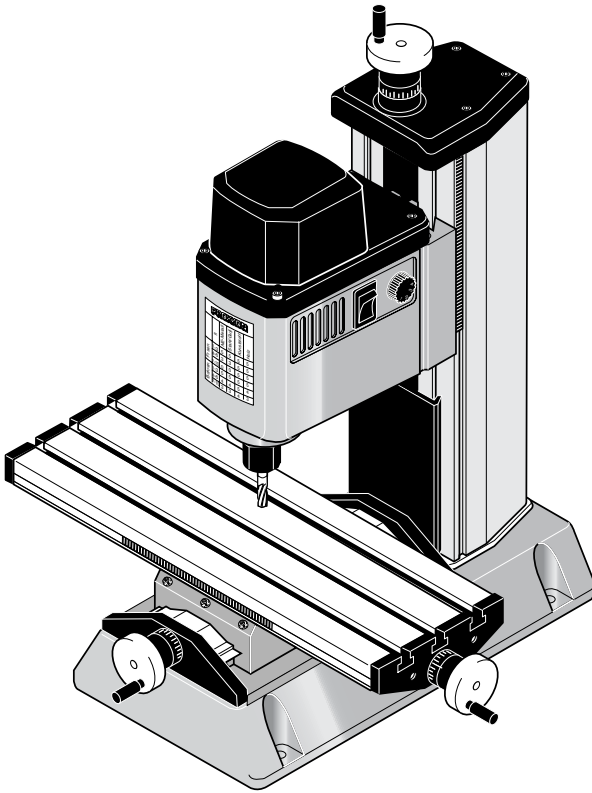

**Manual**

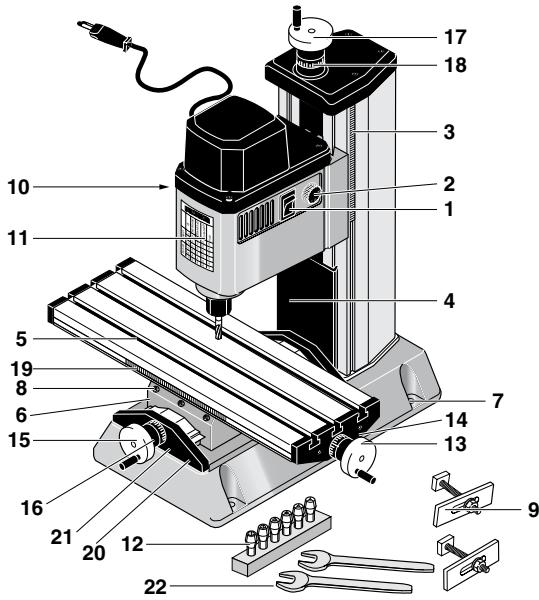

Fig. 1

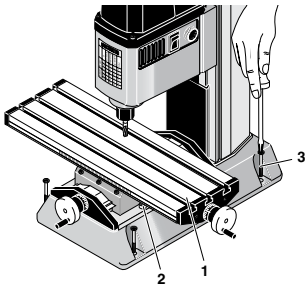

Fig. 2

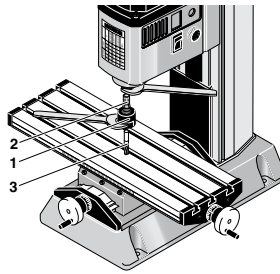

Fig. 4

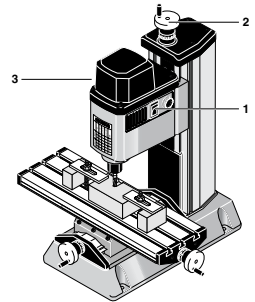

Fig. 4

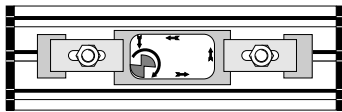

Fig. 5

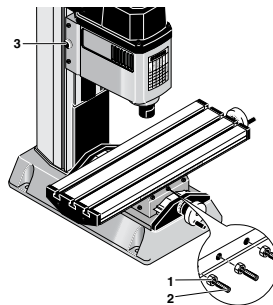

Fig. 6

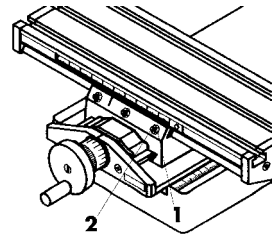

Fig. 7



## Operating Instructions Micro Milling Machine MF 70

Dear Customer,  
By purchasing your PROXXON Micro Milling Machine MF 70, you have chosen a good-quality, high-grade machine. The PROXXON MF 70 MICRO Milling Machine is equipped with the proven KT 70 microcoordinate table. This enables you to perform small, precise milling operations on metal, plastics or wood. In order to operate the milling machine and the accompanying accessories safely and correctly, please read the enclosed safety information and operating instructions prior to operation.

This instruction manual covers:

- safety regulations
- operation and maintenance
- spare parts list

### Please read carefully!

Using this instruction manual will

- **make it easier for you** to get used to the machine,
- **help prevent** faults occurring due to improper use and
- **increase** the service life of your machine.

Keep this instruction manual in an easily accessible place. Only operate this machine if you are qualified to do so and follow the guidelines in this instruction manual.

PROXXON does not accept responsibility for the safe functioning of the machine

- if it is handled in a manner which constitutes improper use,
- if it is used for other purposes which are not specified in the instruction manual,
- if the safety regulations are not observed.

Warranty claims are invalid if

- the machine is incorrectly operated,
- the machine has not been sufficiently maintained.

In the interests of your safety, please always observe the safety regulations.

Only use genuine PROXXON spare parts.

We reserve the right to make further alterations for the purpose of technical progress.

We wish you every success with your machine.

## General safety instructions:

---

1. REMOVE ADJUSTING KEYS AND WRENCHES. Form habit of checking to see that keys and adjusting wrenches are removed from tool before turning it on.
2. KEEP WORK AREA CLEAN. Cluttered areas and benches invite accidents.
3. DON'T USE IN DANGEROUS ENVIRONMENT. Don't use power tools in damp or wet locations, or expose them to rain. Keep work area well lighted.
4. KEEP CHILDREN AWAY. All visitors should be kept safe distance from work area.
5. MAKE WORKSHOP KID PROOF with padlocks, master switches, or by removing starter keys.
6. DON'T FORCE TOOL. It will do the job better and safer at the rate for which it was designed.

7. USE RIGHT TOOL. Don't force tool or attachment to do a job for which it was not designed.
8. USE PROPER EXTENSION CORD. Make sure your extension cord is in good condition. When using an extension cord, be sure to use one heavy enough to carry the current your product will draw. An undersized cord will cause a drop in line voltage resulting in loss of power and overheating. Table 1 shows the correct size to use depending on cord length and name-plate ampere rating. If in doubt, use the next heavier gage. The smaller the gage number, the heavier the cord.  
Exception No. 1: The reference to the table and the table itself may be omitted if a statement indicating the appropriate gage and length is incorporated into the instruction.  
Exception No. 2: The information regarding extension cords need not be provided for a permanently connected tool.
9. WEAR PROPER APPAREL. Do not wear loose clothing, gloves, neckties, rings, bracelets, or other jewelry which may get caught in moving parts. Non-slip footwear is recommended. Wear protective hair covering to contain long hair.  
Exception: The reference to gloves may be omitted from the instructions for a grinder.
10. ALWAYS USE SAFETY GLASSES. Also use face or dust mask if cutting operation is dusty. Everyday eyeglasses only have impact resistant lenses, they are NOT safety glasses.
11. SECURE WORK. Use clamps or a vise to hold work when practical. It's safer than using your hand and it frees both hands to operate tool.
12. DON'T OVERREACH. Keep proper footing and balance at all times.
13. MAINTAIN TOOLS WITH CARE. Keep tools sharp and clean for best and safest performance. Follow instructions for lubricating and changing accessories.
14. DISCONNECT TOOLS before servicing; when changing accessories, such as blades, bits, cutters, and the like.
15. REDUCE THE RISK OF UNINTENTIONAL STARTING. Make sure switch is in off position before plugging in.
16. USE RECOMMENDED ACCESSORIES. Consult the owner's manual for recommended accessories. The use of improper accessories may cause risk of injury to persons.
17. NEVER STAND ON TOOL. Serious injury could occur if the tool is tipped or if the cutting tool is unintentionally contacted.
18. CHECK DAMAGED PARTS. Before further use of the tool, a guard or other part that is damaged should be carefully checked to determine that it will operate properly and perform its intended function -- check for alignment of moving parts, binding of moving parts, breakage of parts, mounting, and any other conditions that may affect its operation.  
A guard or other part that is damaged should be properly repaired or replaced.
19. DIRECTION OF FEED. Feed work into a blade or cutter against the direction of rotation of the blade or cutter only.
20. NEVER LEAVE TOOL RUNNING UNATTENDED. TURN POWER OFF. Don't leave tool until it comes to a complete stop.

## GROUNDING INSTRUCTIONS:

### 1. All grounded, cord-connected tools:

In the event of a malfunction or breakdown, grounding provides a path of least resistance for electric current to reduce the risk of electric shock. This tool is equipped with an electric cord having an equipment-grounding conductor and a grounding plug. The plug must be plugged into a matching outlet that is properly installed and grounded in accordance with all local codes and ordinances. Do not modify the plug provided -- if it will not fit the outlet, have the proper outlet installed by a qualified electrician.

Improper connection of the equipment-grounding conductor can result in a risk of electric shock. The conductor with insulation having an outer surface that is green with or without yellow stripes is the equipment-grounding conductor. If repair or replacement of the electric cord or plug is necessary, do not connect the equipment-grounding conductor to a live terminal. Check with a qualified electrician or service personnel if the grounding instructions are not completely understood, or if in doubt as to whether the tool is properly grounded.

Use only 3-wire extension cords that have 3prong grounding plugs and 3pole receptacles that accept the tool's plug.

Repair or replace damaged or worn cord immediately.

### 2. Grounded, cord-connected tools intended for use on a supply circuit having a nominal rating less than 150 volts:

This tool is intended for use on a circuit that has an outlet that looks like the one illustrated in Sketch A in Figure 28. The tool has a grounding plug that looks like the plug illustrated in Sketch A in Figure 28. A temporary adapter, which looks like the adapter illustrated in Sketches B and C, may be used to connect this plug to a 2-pole receptacle as shown in Sketch B if a properly grounded outlet is not available. The temporary adapter should be used only until a properly grounded outlet can be installed by a qualified electrician. The green-colored rigid ear, lug, and the like, extending from the adapter must be connected to a permanent ground such as a properly grounded outlet box.

### Grounding methods

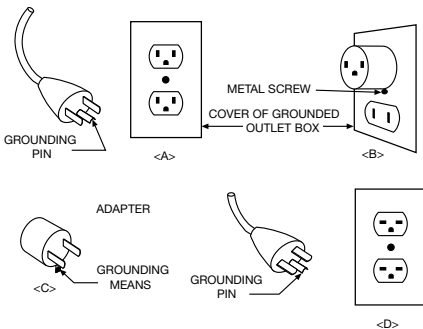

Fig. 28

Table 1

Minimum gage for cord

Effective date for Table 1 changed from November 1, 1995 to November 11, 1996

Ampere Rating		Volts		Total length of cord in feet			
		120 V	25 ft.	50 ft.	100 ft.	150 ft.	
		240 V	50 ft.	100 ft.	200 ft.	300 ft.	
More Than	Not More Than	AWG					
0	6		18	16	16	14	
6	10		18	16	14	12	
10	12		16	16	14	12	
12	16		14	12	Not Recommended		

### Additional safety instructions :

This milling machine is for indoor use only. Do not expose to rain or use in damp locations.

Use only accessories recommended for this milling machine. Follow the instructions that accompany accessories. Use of improper accessories may cause hazards.

Do not attempt to modify this tool or create accessories not recommended for use with this tool. Any such alternation or modification is misuse and could result in hazardous condition leading to possible serious injury.

To avoid injury from unexpected starting or electrical shock, do not plug the power cord into a power source receptacle during unpacking and assembly. This cord must remain unplugged whenever you are working on the milling machine.

If any part is missing or damaged, do not plug the milling machine in until the missing or damaged part is replaced, and assembly is complete. To avoid electrical shock, use only identical replacement parts when servicing grounded tools.

For your safety, never connect the plug to the power source receptacle until the assembly and adjustment steps are completed, and you have read and understood the safety and operating instructions.

To avoid injury from accidental start, make sure the switch is in the OFF position and the plug is not connected to the power source receptacle before changing any parts or tools (i. e. miller)

To avoid injury from accidental start, make sure the switch is in the OFF position and the plug is not connected to the power source receptacle before making any adjustments.

For your own safety, do not plug the tool into the power source receptacle or insert the switch key, until the parts are correctly installed and adjustments have been made.

For your own safety, use only millers sized and recommended for this milling machine. Follow the instructions that accompany the millers.

To avoid fire or toxic reaction, never use gasoline, naphtha, acetone, lacquer thinner, or similar highly volatile solvents to clean the milling machine.

Do not allow brake fluids, gasoline, or penetrating oils to come in contact with the plastic parts. They contain chemicals that can damage or destroy plastics.

Only qualified service technicians should do all electrical or mechanical repairs.

When servicing use only PROXXON replacement parts. Use of any other parts may create a hazard or cause product damage.

Any attempt to repair or replace electrical parts on this lathe may create a hazard unless repair is done by a qualified service technician. Repair service is available at your PROXXON service center (You find the address at the back of this manual)

## General view (Fig. 1):

1. On / Off switch
2. Speed control
3. Scale for Z direction
4. Spindle cover
5. KT 70 work table (210 mm x 70 mm)
6. Support
7. Hole for securing base
8. Adjusting screws
9. Clamps
10. Clamp screw
11. Table for spindle speeds
12. Collet chucks
13. Handwheel for X direction
14. Scale ring for X direction
15. Handwheel for Y direction
16. Scale ring for Y direction
17. Handwheel for Z direction
18. Scale ring for Z direction
19. Moving scale for X direction
20. Base plate
21. Cutting guard
22. Spanners

## Description of the machine

The PROXXON MF 70 MICRO Milling Machine is the ideal machine for all fine and precision milling work for metals (cast iron, steel, brass, aluminium), plastics or wood. With the high spindle speed of 5,000 to 20,000 rpm (enabling the use of the smallest milling cutter diameters) in conjunction with the high-precision KT 70 microcoordinate table, all pre-conditions for precise and clean operation are fulfilled.

The basic equipment includes:

- Milling spindle with Z-pillar and stable base
- Collet chuck block with collet chucks
- (Ø 1.0; 1.5; 2.0, 2.4; 3.0 and 3.2 mm)
- KT 70 microcoordinate table, complete
- Clamp set with fastening materials
- Fastening screws for KT 70 micro coordinate table
- Auxiliary tools
- Operating instructions and safety regulations

- 6 -

## Technical data

Voltage:	115 Volts, 60 Hz
Power rating:	100 watt
Only for indoor use.	
Spindle speed	5,000 – 20,000 rpm
Vertical adjustment travel	70 mm
Lateral adjustment travel	134 mm
Longitudinal adjustment travel	46 mm
Table size:	200 x 70 mm
Scale rings:	1 turn = 1 mm
	1 graduation line = 0.05 mm
Dimensions of T-grooves:	12 x 6 x 5 mm
Spacing of T-grooves:	25 mm
Size of base:	130 x 225 mm
Overall height:	340 mm
Weight approx.	7 kg
Noise emission:	≤ 70 dB(A)
Vibration	≤ 2.5 m/s <sup>2</sup>

## Assembly of the milling machine

### **Warning:**

To avoid injury from unexpected starting or electrical shock, do not plug the power cord into a power source receptacle during unpacking and assembly. This cord must remain unplugged whenever you are working on the milling machine.

- Attach the compound-type table **1** (Fig. 2) to the base **2** with the 4 x M4 Allen screws supplied.
- The milling machine must now be fastened to a stable work surface with 4 screws **3**.

## Operation

### Installation of the collet chucks

#### **Important:**

Disconnect the mains plug before changing tools. Tightening the union nut without a suitable shank inserted, damages the collet chuck.

1. Block the spindle with a spanner and release union nut **1** (Fig. 3).
2. Insert the required collet chuck **2** using suitable inserting tool **3**.
3. Block milling spindle and re-tighten union nut.

#### **Note:**

All inserting tools must be tightened with as little protrusion as possible. Excessively protruding shanks vibrate and cause poor milling results.

### Setting the spindle speed

The spindle speed can be adjusted continuously by means of the electronic control.

In general:

Large milling tool diameter = low speed  
Small milling tool diameter = high speed

The correct spindle speeds are indicated on the table on the front of the milling machine.

### Milling

#### **Warning:**

Use only accessories recommended for this milling machine. Follow the instructions that accompany accessories. Use of improper accessories may cause hazards.

Warning:

Do not attempt to modify this tool or create accessories not recommended for use with this tool. Any such alternation or modification is misuse and could result in hazardous condition leading to possible serious injury.

Important

Always wear protective goggles when milling. Always observe the enclosed safety regulations.

1. Fasten the work piece with the clamps supplied or in a vice.
2. Switch on milling machine at switch **1** (Fig. 4).
3. Adjust the required milling depth using handwheel **2**.  
(1 turn = 1 mm feed)
4. Tighten clamp screw **3**.
5. Work with a suitable feed and with a suitable milling depth. The feed must always be against the cutting direction of the milling tool (Fig. 5).
6. Release clamp screw **3** before readjusting the cutting depth (Fig. 4).

#### **Note:**

The MF 70 MICRO Milling Machine is designed for precise, fine machining. Therefore, adopt suitable milling depth and feed rate. Otherwise, poor quality milling results are to be expected. Furthermore, thermal damage may be caused to the electric motor due to continuous overloading.

### Adjustment of scale on compound-type table:

#### **Warning:**

**Disconnect the mains plug before making any adjustments.**

The scale rings on the handwheels are moveable and can thus be set to zero without traversing the table. In addition to the scale rings, the KT 70 micro-compound-type table is equipped with a moveable scale for adjustment in the X direction 19 (Fig. 1).

### Maintenance

#### Adjustment of guide play

#### **Warning:**

**Disconnect the mains plug before making any adjustments.**

All 3 axes of the milling machine are equipped with an adjustable dovetail guide. If, after a time, a guide is found to have too much or too little play, the play can be reset via the adjusting screws (Fig. 7). In order to adjust the play in the X direction, first release the nut **1** (Fig. 7). Then set the play using the set screws **2**. Lock by re-tightening the nut **1**. Adjustment of play for the other two axes is performed analogously.

#### **Note:**

Do not over-tighten the set screws as, otherwise, the guide may be damaged. Evenly tighten all the set screws.

### Accessories recommended for use with this tool

---

Set of carbide millers	No. 27116
Carbide miller	No. 28759